



smartfarm 

Mooring Equipment



High Holding Power Anchor—Triangel Anchor

Ca. Mass (kg)	L mm	W1	W2	W3	W5	d1	b	Proof Load (KN)
50	420	535	375	465	175	22	36	23
100	840	1 075	750	930	357	24	40	39
150	900	1 150	800	1 000	382	32	44	51
300	1 080	1 380	960	1 200	457	45	62	79
500	1 350	1 725	1 200	1 500	270	48	71	116
750	1 530	1 950	1 360	1 700	650	50	75	158
1 000	1 600	2 107	1 424	1 780	680	50	83	199
1 500	2 000	2 634	1 780	2 225	846	68	102	278
2 000	2 100	2 765	1 869	2 336	886	74	112	349
2 500	2 200	2 897	1 958	2 448	937	82	120	414
3 000	2 300	3 029	2 047	2 560	980	82	123	474
3 500	2 580	3 397	2 296	2 870	1 094	90	130	528
4 000	2 700	3 555	2 403	3 004	1 141	90	136	577
4 500	2 815	3 707	2 505	3 132	1 186	100	146	622
5 000	3 020	3 977	2 688	3 360	1 267	100	150	661

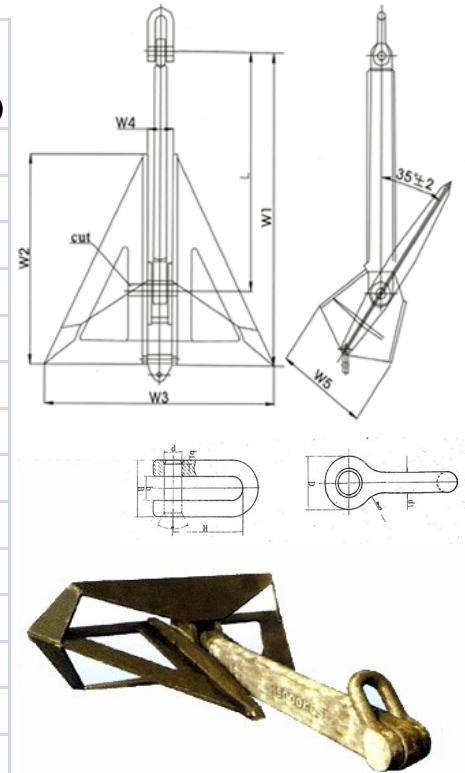



Pool N Type Anchor

Weight kg	Dimensions in mm					
	A	B	C	D	E	F
20	385	325	298	75	455	185
40	480	410	372	95	570	235
60	555	470	429	110	655	270
80	608	515	470	120	720	295
100	655	555	506	130	775	320
120	698	595	540	135	825	340
160	765	650	592	150	905	370
180	795	675	615	155	940	385
200	825	700	640	160	978	400
240	880	745	680	175	1 040	425
280	925	780	715	180	1 092	450
320	964	820	745	190	1 140	470
360	1 005	855	780	195	1 190	490
400	1 040	885	805	205	1 230	505
440	1 074	910	830	210	1 270	520
480	1 105	940	855	215	1 305	535
520	1 133	960	875	220	1 340	550
600	1 190	1 010	920	235	1 410	580
800	1 313	1 115	1 015	255	1 550	635
900	1 365	1 160	1 055	270	1 615	665
1 000	1 410	1 200	1 090	275	1 670	670

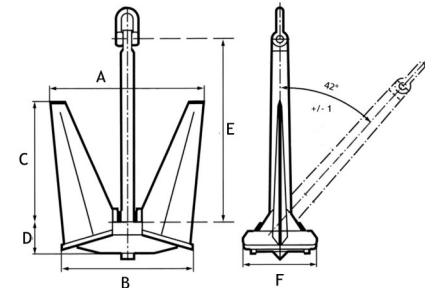



AC - 14 Anchor

High Holding Power Anchor

Nominal Weight kg	Dimensions in mm					
	A	B	C	D	E	F
56	612	555	170	376	113	298
100	745	675	200	458	135	364
135	745	675	205	458	135	364
180	909	822	252	558	166	442
225	1 010	915	277	623	185	495
250	1 010	915	280	623	185	495
270	1 040	940	288	638	190	508
300	1 075	975	298	660	200	525
315	1 075	975	300	660	200	525
340	1 120	1 015	310	690	205	548
360	1 120	1 015	313	690	205	548
428	1 213	1 098	336	745	222	590
495	1 255	1 135	348	770	230	610
590	1 350	1 220	375	829	246	658
675	1 412	1 278	390	868	257	690
765	1 470	1 335	408	906	269	718
910	1 560	1 410	430	957	284	760
970	1 592	1 445	440	978	292	775
1 080	1 650	1 495	455	1 014	302	805
1 200	1 710	1 545	470	1 050	315	835

Mooring Equipment E15-1

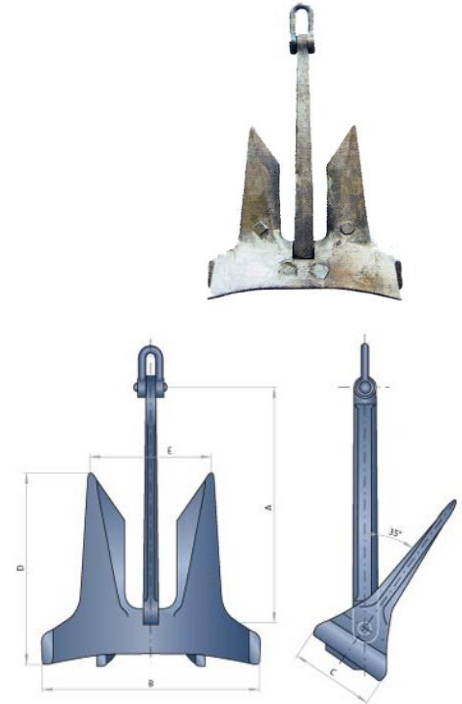



Danforth Anchors - High Holding Power Anchor

Nominal Weight	Dimensions in mm					
	A	B	C	D	E	F
20	130	280	540	370	690	170
30	148	330	620	430	790	200
40	160	360	680	470	860	220
50	172	390	720	510	940	230
60	186	408	755	535	985	240
75	200	450	830	590	1 080	260
100	216	490	930	640	1 180	290
120	220	505	970	670	1 230	300
125	234	520	1 000	690	1 270	310
150	242	550	1 060	732	1 348	330
200	266	600	1 150	810	1 490	360
250	294	650	1 240	870	1 600	390
276	396	660	1 250	885	1 620	400
300	312	690	1 320	925	1 700	420
400	342	750	1 460	1 010	1 810	460
500	368	800	1 570	1 100	2 020	490
750	414	910	1 800	1 260	2 300	560
1 000	450	980	1 980	1 380	2 540	620

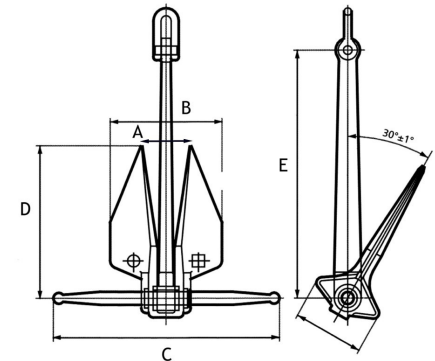
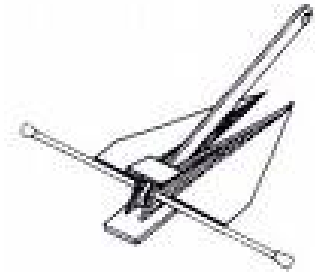



Chain; Studless Link Chain

SIZE OF LINK			SIZE OF LINK			Grade 2	Grade 2
D	L	B	l	b			
Diameter Ø	Outside Lenght	Outside Width	Inside Pitch Lenght	Inside Pitch Width	Weight Ca.	Proof Load	Breaking Load
mm	mm	mm	mm	mm	Kg/m	KN	KN
8	48	28	32	12	1,25	16,50	33,00
10	60	35	40	15	1,95	25,80	51,60
11	66	38,5	44	16,5	2,37	31,20	62,40
12,5	75	43,75	50	18,75	3,07	41,20	82,60
14	84	49	56	21	3,86	51,00	101,90
16	96	56	64	24	5,04	66,20	132,30
17,5	105	61,25	70	26,3	6,03	78,89	157,78
19	114	66,5	76	28,5	7,11	93,60	187,20
20,5	123	71,8	82	30,8	8,27	108,64	217,27
22	132	77	88	33	9,55	125,40	250,90
24	144	84	96	36	11,36	149,90	298,90
26	156	91	104	39	13,34	175,40	350,80
28	168	98	112	42	15,41	203,80	406,70
30	180	105	120	45	17,77	234,20	467,50
32	192	112	128	48	20,12	265,60	531,20
34	204	119	136	51	22,65	299,90	599,80
36	216	126	144	54	25,42	336,10	672,30
38	228	133	152	57	28,51	374,40	748,70
40	240	140	160	60	31,64	414,50	829,10

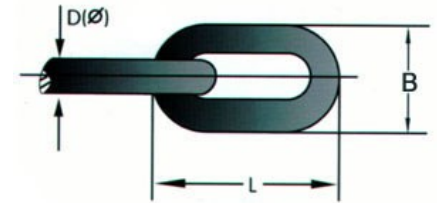



Chain; Stud Link Chain

D Ø	Outside	Outside	Inside	Inside	Links pr. 27,5	Grade 2	Grade 2	Weight Ca. Kg/m
	L	B	l	b		Proof Load KN	Breaking Load KN	
mm	mm	mm	mm	mm	m			
12,5	75	45	50	20	545	66	92	3,42
14	84	50,4	56	22,4	489	82	116	4,29
16	96	57,6	64	25,6	425	107	150	5,61
17,5	105	63	70	28	389	127	179	6,71
19	114	68,4	76	30,4	357	150	211	7,91
20,5	123	73,8	82	32,8	331	175	244	9,20
22	132	79,2	88	35,2	307	200	280	10,60
24	144	86,4	96	38,4	283	237	332	12,61
26	156	93,6	104	41,6	261	278	389	14,80
28	168	100,8	112	44,8	243	321	449	17,17
30	180	108	120	48	225	368	514	19,71
32	192	115,2	128	51,2	211	417	583	22,43
34	204	122,4	136	54,4	199	468	655	25,32
36	216	129,6	144	57,6	189	523	732	28,38
38	228	136,8	152	60,8	179	581	812	31,62
40	240	144	160	64	169	640	896	35,04

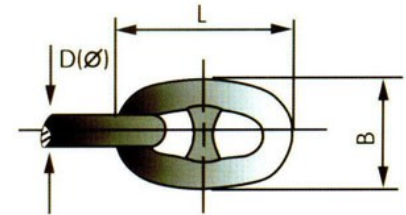



Shackles S-2130 & S 2150

Shackle Size (in)	WLL (ton)	A	B	C	D	E	F	G	H	K	L	M	N	P	R
1/2	2	20,6	16,0	47,8	12,7	33,3	30,2	41,4	83,3	77,0	58,7	46,0	12,7	71,1	12,7
3/4	4 3/4	31,8	22,4	71,4	19,1	50,8	46,0	60,5	126,2	115,1	88,9	69,9	20,6	103,4	20,6
7/8	6 1/2	36,6	25,4	84,1	22,4	57,9	53,1	71,4	148,1	135,4	102,4	81,0	24,6	119,6	24,6
1	8 1/2	42,9	28,7	95,3	25,4	68,3	60,5	81,0	166,6	150,9	126,0	93,7	26,9	134,9	25,4
1 1/8	9 1/2	46,0	31,8	108,0	28,7	73,9	68,3	90,9	189,7	172,2	131,1	103,1	31,8	129,3	31,8
1 1/4	12	51,6	35,1	119,1	31,8	82,6	76,2	100,1	209,6	190,5	146,1	115,1	35,1	165,4	35,1
1 3/8	13 1/2	57,2	38,1	133,4	35,1	92,2	84,1	111,3	232,7	210,3	162,1	127,0	38,1	183,1	38,1
1 1/2	17	60,5	41,4	146,1	38,1	98,6	92,2	122,2	254,0	230,1	174,8	136,7	41,1	196,3	41,1

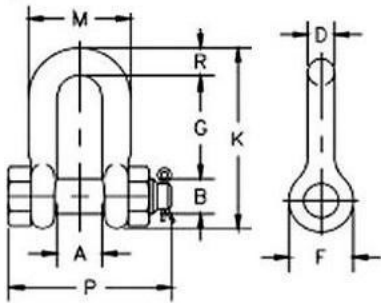

G-2150 / S-2150

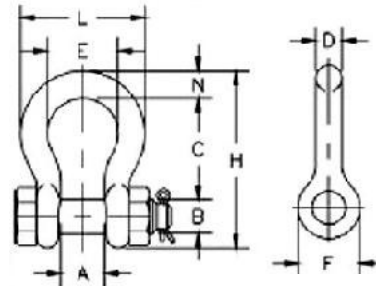

G-2130 / S-2130



Thimbles

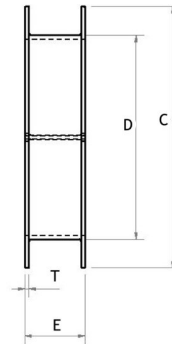
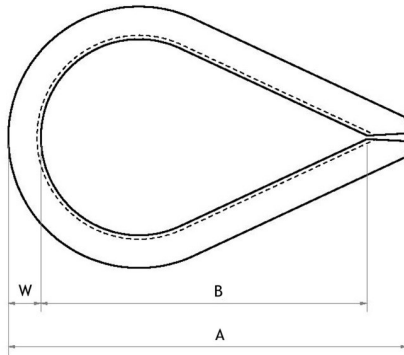

Rope dia.	Dimensions (mm)						
mm	A	B	C	D	E	T	W
16	89,00	57,00	60,50	35,00	23,00	3,10	11,90
20	95,00	63,50	68,30	41,40	28,00	3,75	12,15
26	167,00	108,00	95,00	63,50	35,50	4,25	15,28
32	188,00	114,00	109,00	69,00	44,50	5,75	18,30
36	200,00	191,00	145,00	90,00	48,50	6,00	20,88
40	248,00	230,00	176,00	110,00	57,00	6,50	25,90
45	264,00	243,00	180,00	110,00	60,00	7,00	26,90
50	289,00	270,00	188,00	114,00	66,00	6,50	30,90



4 Strands Rope



8 Strands



Rope diameter (mm)	4 strands		4 strands	
	Polyethylene		Polypropylene	
	Weight (kg/200m)	Strenght (ton)	Weight (kg/200m)	Strenght (ton)
4	1,6	0,19	1,7	0,27
6	3,6	0,37	4,1	0,55
8	6,5	0,66	7,4	0,94
10	9,8	1,01	11,9	1,53
12	14,4	1,43	16,4	2,01
14	19,0	1,94	20,8	2,70
16	26,6	2,60	30,4	3,88
18	32,2	3,22	37,8	4,74
20	40,0	3,97	46,1	5,55
22	48,6	4,72	56,8	6,94
24	59,0	5,67	65,3	7,96
26	65,6	6,45	76,1	9,28
28	78,6	7,63	89,0	10,35
30	92,0	8,81	100,0	12,14
32	105,0	9,95	117,8	13,11
34	118,0	11,24	128,2	14,74
36	132,0	12,51	146,2	16,11
38	144,0	13,83	162,0	18,23
40	157,0	15,74	181,2	20,50

Rope diameter (mm)	8 strands		8 strands	
	Polyethylene		Polypropylene	
	Weight (kg/300m)	Strenght (ton)	Weight (kg/300m)	Strenght (ton)
12	21,3	1,50	20,0	1,81
14	30,8	2,17	28,8	2,42
16	38,0	2,64	36,6	3,07
18	49,8	3,43	46,5	3,82
20	29,3	4,05	59,9	4,64
22	72,8	4,92	73,2	5,61
24	85,4	5,72	93,1	6,53
26	101,1	6,66	99,8	7,56
28	117,0	7,62	143,7	11,83
30	132,8	8,57	148,7	13,57
32	151,5	9,70	180,0	15,76
34	171,0	10,80	195,2	16,10
36	196,5	12,20	217,0	17,84
38	214,5	13,20	255,7	19,50
40	240,0	14,60	274,5	21,01
45	303,0	17,90	333,6	26,32
50	366,0	20,90	407,5	29,25
55	454,5	25,60	432,0	34,68
60	543,0	30,30	510,0	35,90
70	720,0	39,20	678,0	47,70
80	948,0	50,40	891,0	61,10



Pullropes / Anchor back rope

These ropes are used for tensioning the SmartUnits by pulling back the anchor. The pullropes are made in 8 strands rope with thimble in one end and a proper spliced soft eye in the other end.

The end with the thimble connects to the back of the anchor with a shackle, a few meters above we recommend attaching a small buoy (8-40 litres) to the pullrope. In the surface a buoy between 30 and 140 litres are attached to the pullrope. The soft eye in the surface are easy to attach to the boats pulpit before tensioning. The length and dimensions of the pullrope are set





Mooring buoys

Model/type	Volume liter	Diameter mm	Height mm
Small Mooring Buoy	800	1 150	1 156
Medium Mooring Buoy	1 050	1 150	1 396
Large Mooring Buoy	1 300	1 150	1 640
Small 90 l Buoy	90	550	500

Skin:

- Rotational moulded, polyethylene (LLDPE)
- UV-Stabilized
- Wall thickness: 8 mm

Foam:

- PU, polyurethane
- Density: 35 kg/m³

Mooring Buoy characteristics:

- Steel rod 30 mm
- All steel hot dipped galvanized
- 2 different eye options

Options riddled hole for small 90 l buoy :

- Ø 40 mm
- Ø 50 mm
- Ø 90 mm

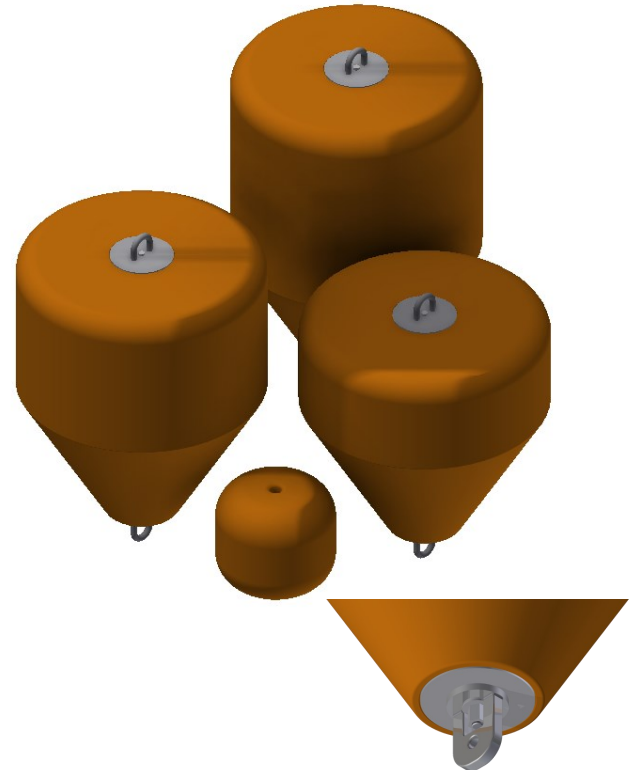



- contact information

Dimensions are guiding and variances may appear.

HDG=Hot dipped galvanized

Head office:

Visiting address:

Smart Farm AS
Støperigata 2
4014 Stavanger, Norway

Tel: +47 51 59 59 15

Fax: +47 51 59 59 14

E-mail: post@smartfarm.no

Postal:

Smart Farm AS
Post Box 1524
4093 Stavanger, Norway

Web: www.smartfarm.no

We look forward to be your solution provider, please contact us for a customized offer.



Smart Farm seeks solutions to meet our customers needs.

Make a **smart** choice ...

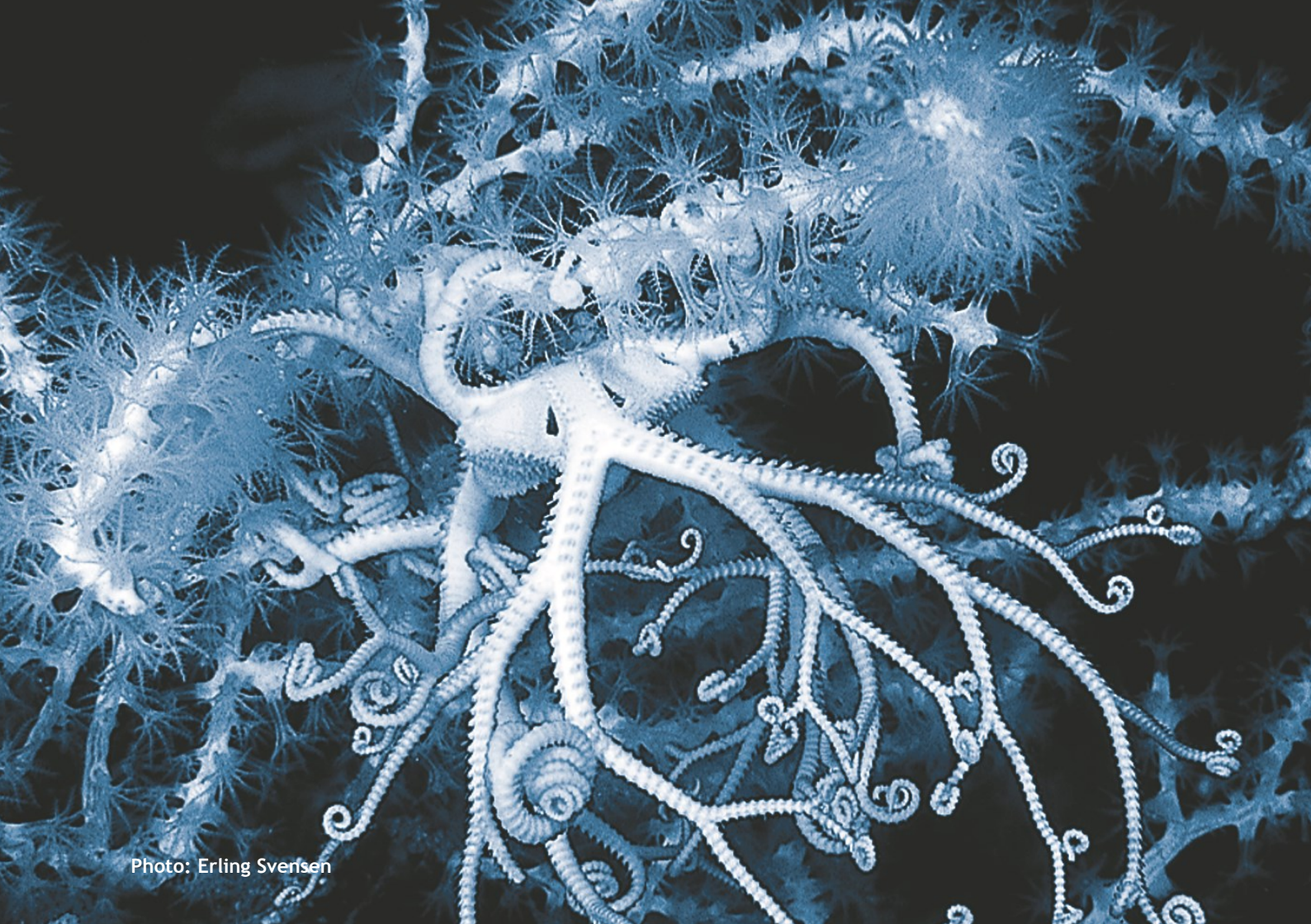

Photo: Erling Sverisen